



FUEL SYSTEM

Section 3B - Carburetors

Table of Contents

Fuel System - Troubleshooting	3B-2	Main Circuit	3B-14
General Information	3B-2	Back Draft Circuit	3B-15
Attenuator And Carb Throttle Levers	3B-4	Carburetor Specifications	3B-16
Fuel Lines	3B-6	Carburetor Placement and Jet Location	
Carburetor	3B-8	for Each Cylinder	3B-17
Carburetor	3B-10	Carburetor Jet Placement	3B-18
Carburetor Fuel Circuits	3B-11	Jet Part Number Chart	3B-18
Float Bowl Circuit	3B-11	Removing Carburetor(s) from Engine	3B-20
Idle Circuit	3B-12	Throttle Shaft Screws	3B-21
Cold Start Circuit	3B-13	Float Adjustment	3B-21
Off-Idle Circuit	3B-13	Installing Carburetor(s) to Engine	3B-22





Fuel System - Troubleshooting

General Information

Problems, that are thought to be caused by the fuel system, may be, in reality, something completely different. Items, that are shown in the list on the right, could give the impression that there is a problem in the fuel system.

1. Impeller
2. Spark plugs
3. Ignition timing
4. Ignition spark voltage
5. Cylinder compression
6. Reed valves

Problem: Engine Turns Over But Will Not Start Or Starts Hard When Cold	
Possible Cause	Corrective Action
Improper starting procedure used.	Check proper starting procedure, as outlined in "Operation and Maintenance Manual."
Fuel tank empty or too low. Improperly mixed fuel. Contaminants (water, dirt, etc.) in fuel	Check fuel in fuel tank and replace or add whichever is necessary.
Fuel tank air vent closed or restricted.	Check air vent on fuel tank. Air vent must be open all-the-way and free from any contaminants.
A pinched, cut or restricted fuel line. Also loose fuel line connection.	Check all fuel lines and replace as needed. Check and tighten all fuel line connections.
Dirty or restricted fuel filter.	Check and replace or clean all fuel filters.
Low fuel pump pressure.	Refer to Section 3A.
An anti-siphon valve.	Refer to "Checking for Restricted Fuel Flow" in Section 3A.
Choke solenoid, or enrichment valve not operating.	Check choke solenoid or valve, and electrical wiring to solenoid or valve. Replace if necessary.
A needle and seat (in carburetor) that is either stuck open or closed. Open=Flooding - Closed=Starving	Refer to "Carburetor Disassembly" in this section.
Improper carburetor jets, restricted jet or idle mixture screw out of adjustment.	Refer to "Carburetor Adjustments" in this section.
Improper carburetor float level.	Refer to "Carburetor Adjustments" in this section.



Problem: Engine Idles Rough and Stalls. Problem: Engine Hesitates Upon Acceleration. Problem: Engine Runs Uneven or Surges.	
Possible Cause	Corrective Action
Improperly mixed fuel. Contaminants (water, dirt, etc.) in fuel.	Check fuel in fuel tank and replace if necessary.
Fuel tank air vent closed or restricted.	Check air vent on fuel tank. Air vent must be open all-the-way and free from restrictions.
A pinched, cut or restricted fuel line. Also loose fuel line connection.	Check all fuel lines and replace as needed. Check and tighten all fuel line connections.
A dirty or restricted fuel filter.	Check and replace or clean all fuel filters.
Low fuel pump pressure.	Refer to Section 3A.
An anti-siphon valve.	Refer to Section 3A.
A needle and seat (in carburetor) that is either stuck open or closed. Open=Flooding - Closed=Starving	Refer to "Carburetor Adjustments" in this section.
Improper carburetor jets, restricted jet or idle mixture screw out of adjustment.	Refer to "Carburetor Adjustments" in this section.
Improper carburetor float level.	Refer to "Carburetor Adjustments" in this section.
Carburetor loose on reed block housing.	Tighten carburetor nuts securely.
Reed block housing loose, or gaskets are defective.	Using a pressure oil can, spray 2-cycle oil around reed block housing/crankcase housing matching surfaces and carburetor base. If engine RPM changes, tighten or replace reed block housing gaskets or carburetor base gaskets, as needed.
Improperly routed or restricted bleed hose(s).	Refer to bleed line routing in this section.

REED VALVE SPECIFICATIONS

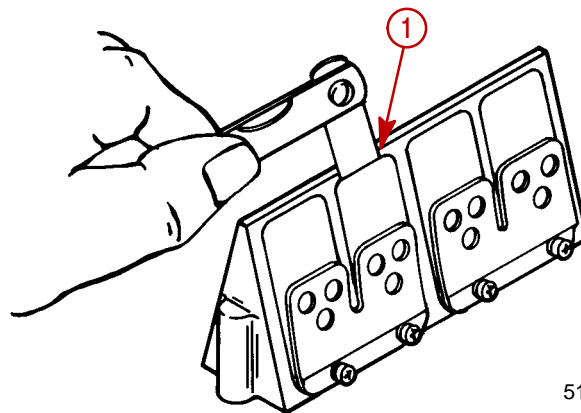

51851

Reed Valve Opening

1 - Max. 0.020 in. (0.59 mm)



Attenuator And Carb Throttle Levers

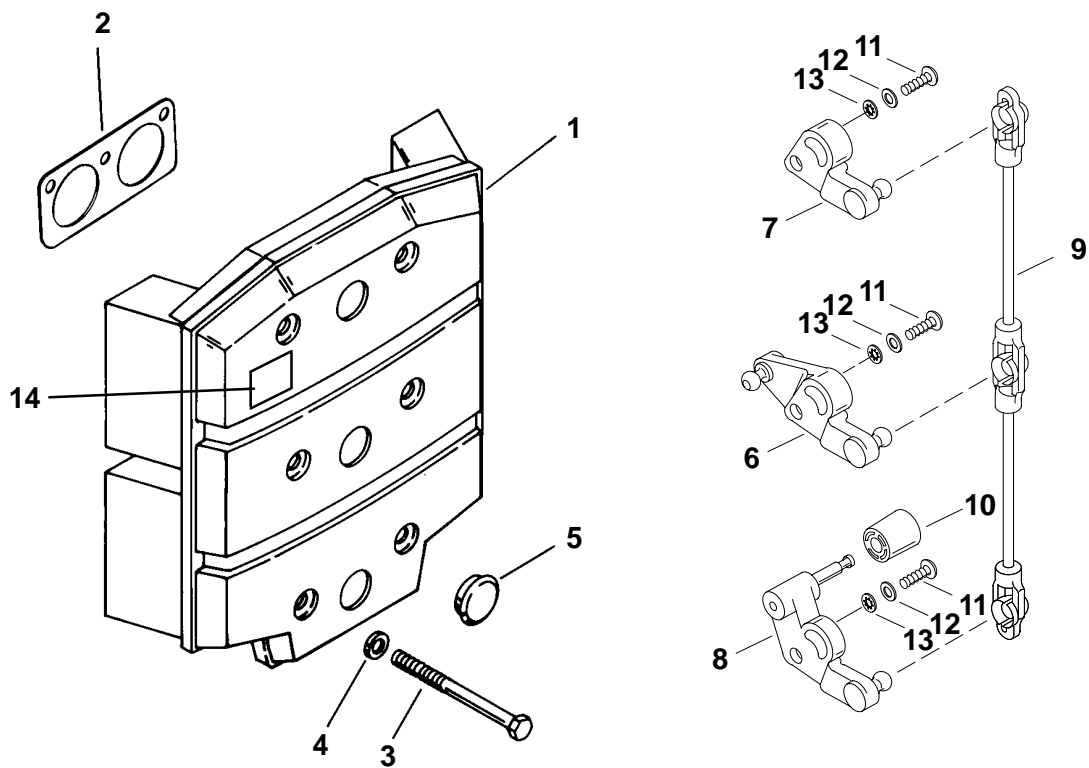



REF. NO.	QTY.	DESCRIPTION	TORQUE		
			lb. in.	lb. ft.	N-m
1	1	ATTENUATOR-Sound			
2	3	GASKET-Attenuator to Carb			
3	6	SCREW (.250-28 x 2.500)	60		7.0
4	6	WASHER			
5	3	CAP			
6	1	LEVER KIT-Throttle			
7	1	LEVER-Throttle			
8	1	LEVER-Throttle			
9	1	LINK-Throttle			
10	1	ROLLER			
11	3	SCREW (#10-32 x .750)			
12	3	WASHER			
13	3	LOCKWASHER (#10 External)			
14	1	DECAL-Caution			



Fuel Lines

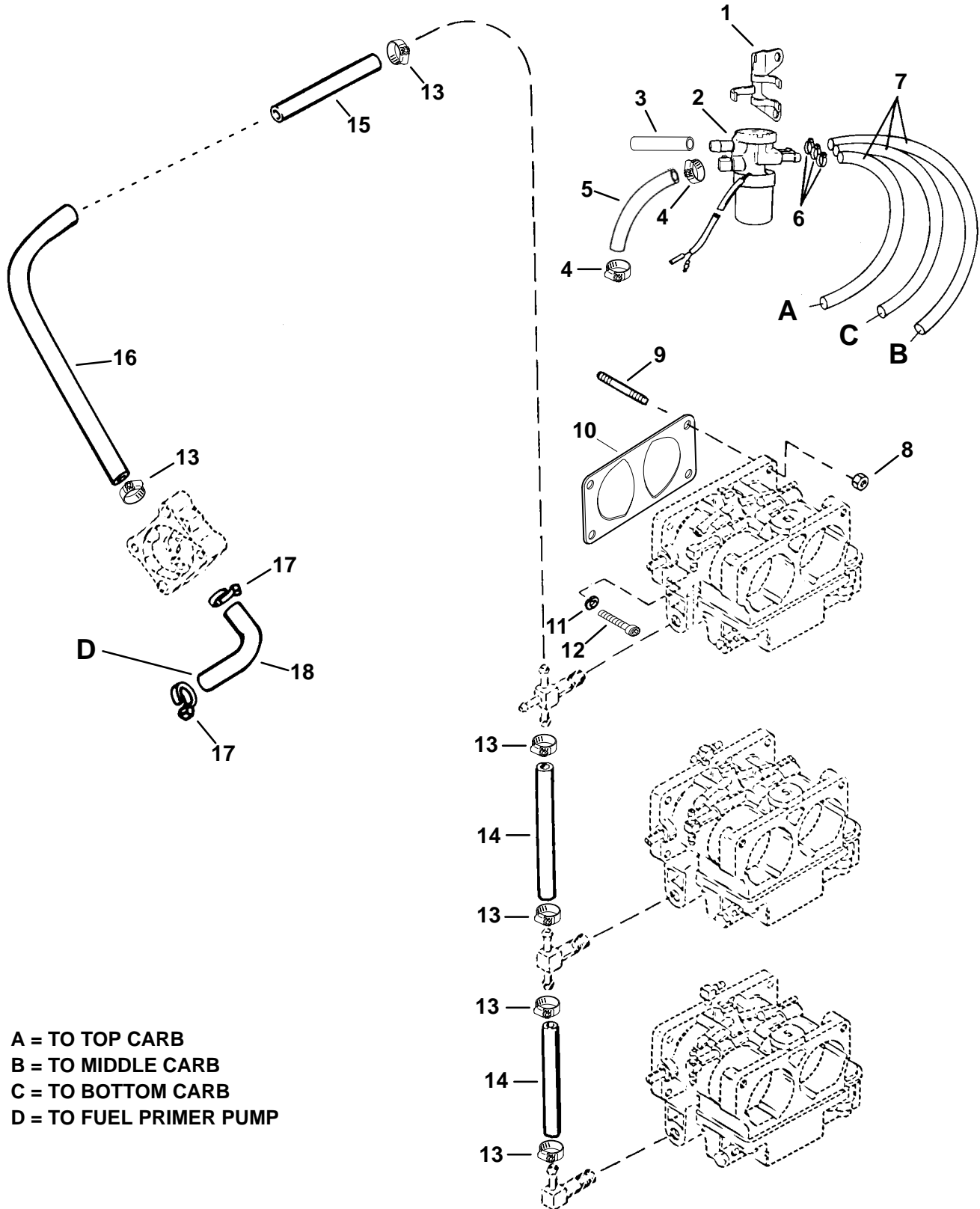

A = TO TOP CARB
 B = TO MIDDLE CARB
 C = TO BOTTOM CARB
 D = TO FUEL PRIMER PUMP



REF. NO.	QTY.	DESCRIPTION	TORQUE		
			lb. in.	lb. ft.	N-m
1	1	BRACKET-Cold Start Solenoid			
2	1	SOLENOID-Cold Start			
3	1	TUBING (28.00 in. Bulk) (Cut 1.750 in.)			
4	2	CLAMP			
5	1	HOSE (2.750 in.)			
6	3	CABLE TIE (8.00 in.)			
7	3	HOSE (26.00 in. Bulk) (Cut 8.750 in.)			
8	6	NUT (.250-28)			
9	6	STUD (.250 x 1.125)			
10	3	GASKET-Carburetor Mount			
11	6	LOCKWASHER (.250)			
12	6	SCREW (.250-20 x .875)			
13	6	CLAMP			
14	2	HOSE (38.00 in. Bulk) (Cut 4.250 in.)			
15	1	HOSE (9.00 in. Bulk) (Cut 8.00 in.)			
16	1	HOSE (9.00 in.)			
17	2	CABLE TIE (8.00 in.)			
18	1	TUBING (15.00 in. Bulk) (Cut 7.500 in.)			



Carburetor

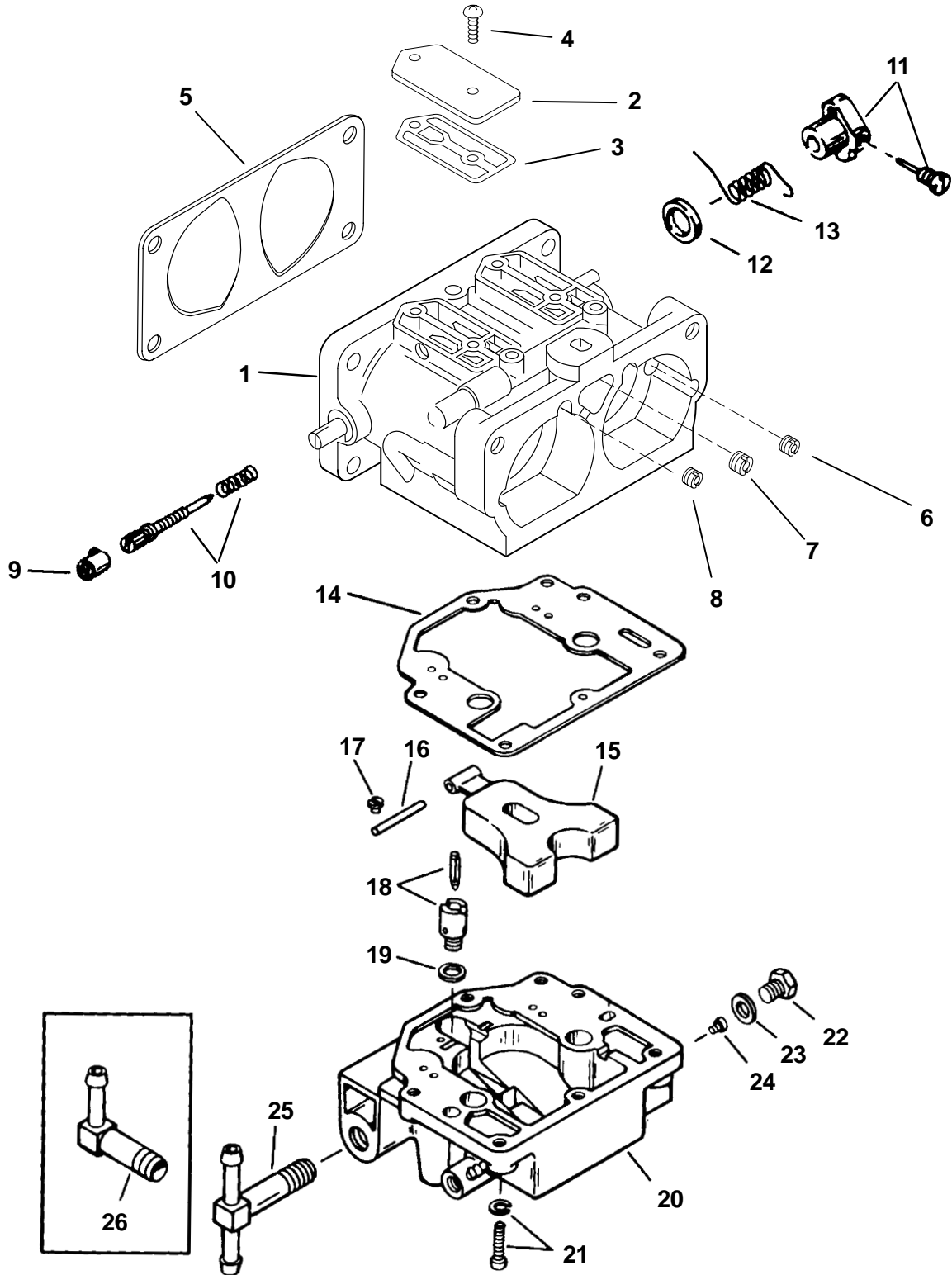



REF. NO.	QTY.	DESCRIPTION	TORQUE		
			lb. in.	lb. ft.	N-m
1	1	CARBURETOR (TOP) (WMV-9-1)			
	1	CARBURETOR (CENTER) (WMV-9-2)			
	1	CARBURETOR (BOTTOM) (WMV-9-3)			
2	6	COVER-Idle Circuit			
3	6	GASKET-Idle Circuit Cover			
4	12	SCREW-Idle Circuit Cover	18		2
5	3	GASKET-Carburetor Mount			
6	2	JET-Idle Air Vent (.050) (TOP & CENTER) (PORT)	15		1.5
	1	JET-Idle Air Vent (.054) (BOTTOM) (PORT)	15		1.5
7	3	JET-Bowl Vent (.080)	15		1.5
8	3	JET-Idle Air Vent (.050) (STARBOARD)	10		1
9	3	CAP-Limiter			
10	6	SCREW & SPRING-Idle Mixture			
11	3	LEVER KIT			
12	3	SPACER			
13	3	SPRING-Throttle Return			
14	3	GASKET-Fuel Bowl			
15	3	FLOAT ASSEMBLY			
16	3	SHAFT-Float			
17	3	SCREW-Float Pin	10		1
18	3	VALVE SEAT KIT			
19	3	GASKET-Valve Seat			
20	1	BOWL-Fuel (TOP)			
	2	BOWL-Fuel (CENTER & BOTTOM)			
21	18	SCREW-Fuel Bowl			
22	6	PLUG KIT-Drain	33		3.5
23	6	GASKET-Drain Plug			
24	6	JET-Main Fuel (.076) (PORT & STBD)	14		1.5
25	2	FITTING-Tee (TOP & CENTER)	45		5
26	1	ELBOW (BOTTOM)	45		5



Carburetor

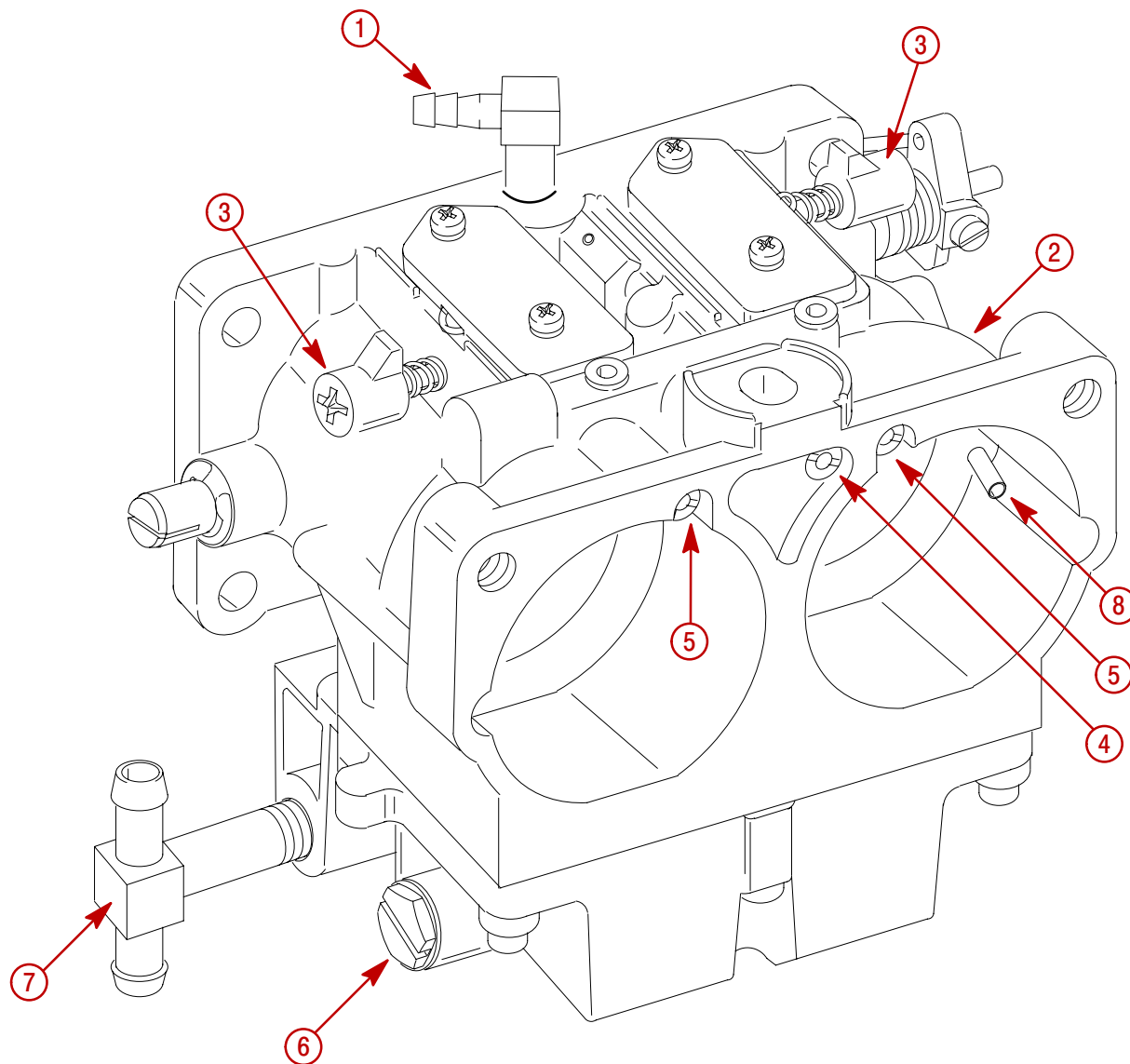

54350

- 1 - Enricher Hose Fitting
- 2 - Carburetor Number
- 3 - Fuel Mixture Adjustment Screw
- 4 - Back Draft Vent Jet
- 5 - Idle Air Bleed Jet
- 6 - High Speed Fuel Jet Access Plug (2)
- 7 - Fuel Line Fitting
- 8 - Main Nozzle Well Vent (2)



Carburetor Fuel Circuits

Float Bowl Circuit

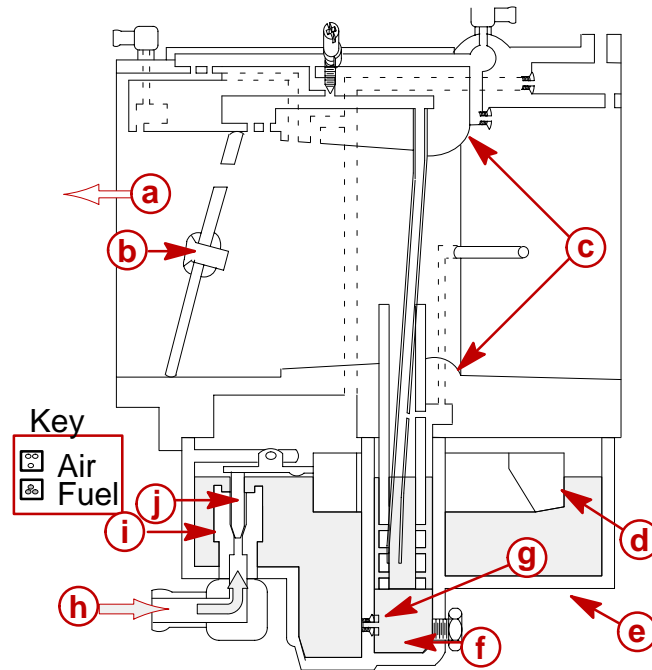

- a** - To Engine Crankcase
- b** - Throttle Plate
- c** - Carburetor Venturi
- d** - Float
- e** - Float Bowl
- f** - Main Fuel Well
- g** - Main Jet
- h** - Fuel from Fuel Pump
- i** - Inlet Seat
- j** - Inlet Needle

Fuel from the fuel pump enters the carburetor through the fuel inlet fitting and fills the bowl until the float moves the inlet needle against the fuel inlet seat. With the inlet needle against the inlet seat, the fuel inside the float bowl is at its maximum level. Fuel inside the bowl flows through the main fuel jet and fills the main fuel well.



Idle Circuit

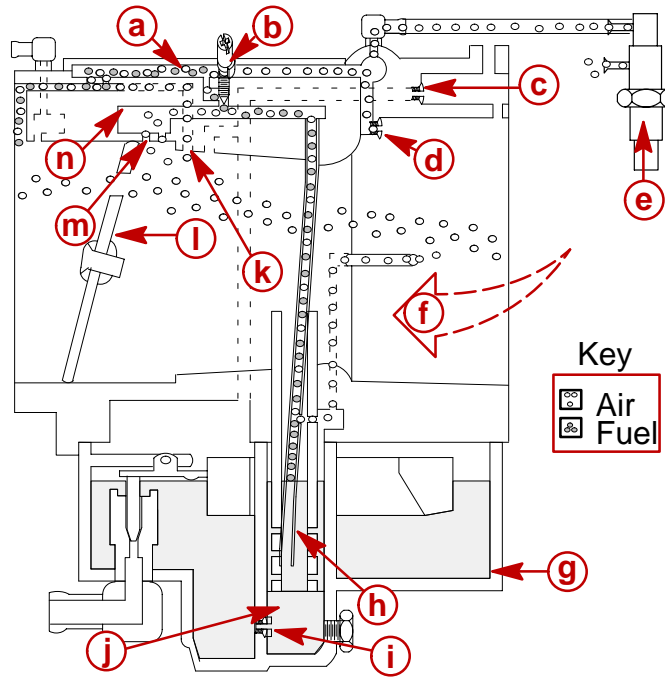

- a** - Idle Passage
- b** - Idle Mixture Screw
- c** - Back Draft Jet
- d** - Idle Air Jet
- e** - Thermal Air Valve (open)
- f** - Air Flow
- g** - Float Bowl
- h** - Idle Tube
- i** - Main Fuel Jet
- j** - Main Fuel Well
- k** - Secondary Idle Air Bleed
- l** - Throttle Plate
- m** - Off-Idle Ports
- n** - Off-Idle Passage

As the engine rotates, the piston moves away from the crankcase. This movement creates a low pressure area behind the throttle plate. Atmospheric pressure pushes air through the carburetor throat (venturi), past the throttle plate (small hole in plate) and into the low pressure area inside the crankcase. Atmospheric pressure enters the float bowl chamber through the back draft jet. This pressure forces fuel toward the low pressure area behind the throttle plate. Fuel flows:

- a. Through the main fuel jet into the main fuel well,
 - (1.) Up the idle tube,
 - (2.) Through the off-idle passages,
 - (3.) Past the idle mixture screw,
 - (4.) Into the idle passage
 - (5.) And into the carburetor throat.

Air enters the idle circuit through the idle air jet and secondary idle air bleed. This air mixes with the fuel inside the idle passage before the air/fuel mixture is discharged into the engine. Rotating the idle mixture screw will change the air/fuel mixture at idle speeds.



Cold Start Circuit

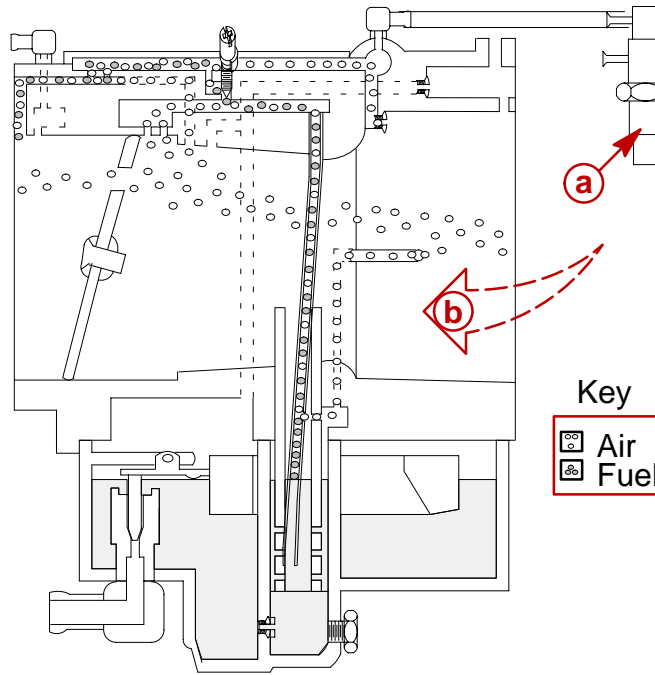

- a** - Thermal Air Valve (closed)
- b** - Air Flow

A cold engine will require a richer mixture. Fuel is supplied to the carburetors by the solenoid operated enricher valve.

Off-Idle Circuit

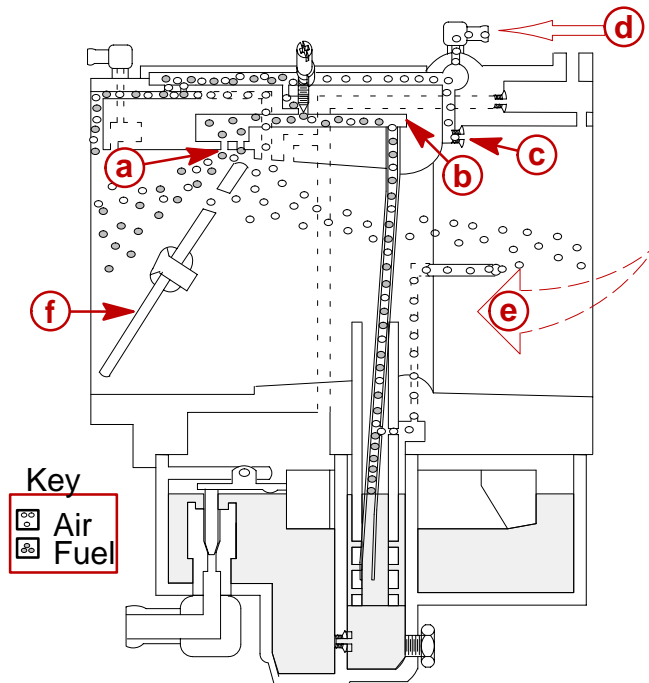

- a** - Off-Idle Ports
- b** - Off-Idle Passage
- c** - Idle Air Jet
- d** - From Open Thermal Air Valve
- e** - Air Flow
- f** - Throttle Plate



As the throttle plates rotate past the off-idle ports, the ports are exposed to the low pressure area behind the throttle plate. Additional fuel flows through the off-idle passage; through the rear port; and as the throttle plate continues to rotate, through the forward port.

Main Circuit

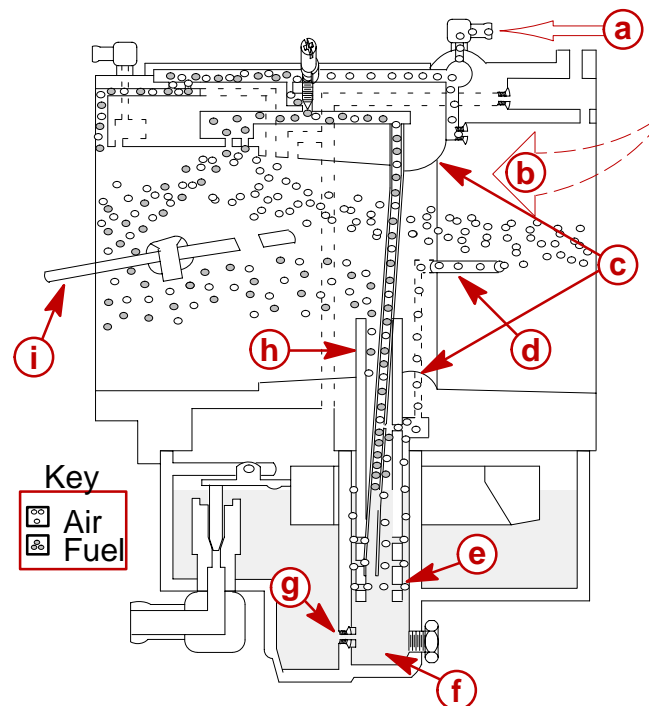

- a** - From Open Thermal Air Valve
- b** - Air Flow
- c** - Venturi
- d** - Main Discharge Air Inlet Tube
- e** - Cross Holes
- f** - Main Fuel Well
- g** - Main Fuel Jet
- h** - Main Discharge Nozzle
- i** - Throttle Plate

As the throttle plate rotates past the off-idle ports, the low pressure area extends to the main discharge nozzle. In addition, the increased air flow through the carburetor bore creates a low pressure area inside the venturi. These combined forces create a strong suction over the main discharge tube. Fuel flows:

1. Through the main fuel jet into the main fuel well,
2. Up the main discharge nozzle,
3. Into the venturi.

Air is mixed with the fuel to make it lighter, air enters the main fuel well through the main discharge air inlet tube. Cross holes are drilled in the main discharge tube, allowing the air to mix with the fuel inside the main well. As the throttle plate continues to open, additional fuel is drawn out of the main discharge tube, exposing additional cross holes. At full throttle, the fuel mixture is controlled by the size of the main fuel jet.



Back Draft Circuit

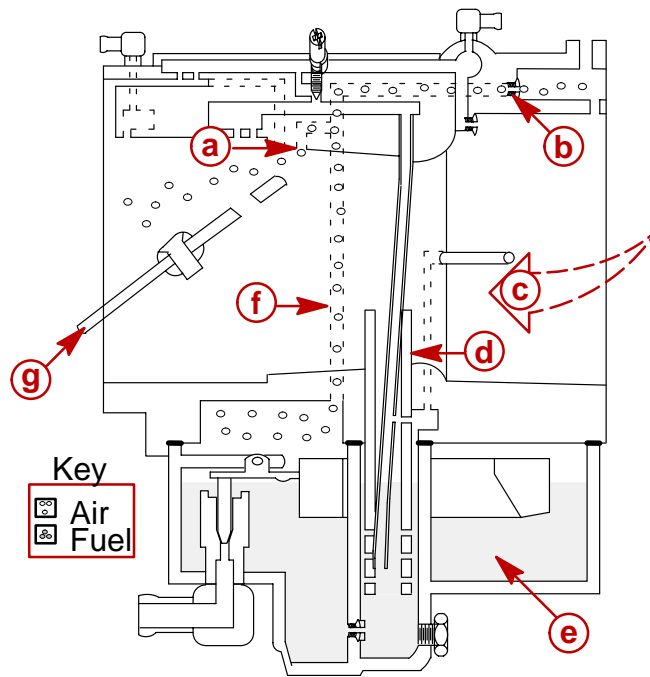

NOTE: Fuel Flow Not Shown For Clarity

- a** - Back Draft Port
- b** - Back Draft Jet
- c** - Air Flow
- d** - Main Discharge Tube
- e** - Fuel Bowl
- f** - Fuel Bowl Vent Passage
- g** - Throttle Plate

At partial throttle settings, the back draft circuit leans out the mixture for increased fuel economy. The back draft circuit uses the float bowl vent circuit and bowl vent jet to lean out the air/fuel mixture. The bowl vent jet limits the amount of air entering the float bowl vent circuit. With the throttle plate positioned correctly, the low pressure area is exposed to the back draft port inside the carburetor bore. The float bowl vent circuit is connected by passages to the back draft port. The low pressure area pulls air out of the bowl vent circuit. Due to the size of the vent jet and the air loss through the back draft port, the air pressure on the fuel inside the fuel bowl is lowered to below atmospheric pressure. Lower pressure on the fuel inside the float bowl, lowers the amount of fuel being forced out of the main discharge tube.



Carburetor Specifications

SYNCHRONIZING CARBURETORS

To synchronize carburetors, refer to “Timing/Synchronizing/Adjusting” section.

IDLE MIXTURE SCREW

For best running quality, the adjustable idle mixture screws are set at the factory with the limit tabs pointing straight up. If adjustment is required, all idle mixture screws must be turned the same amount and the same direction. Turning the idle mixture screws (recommended 1/8 turn at a time) clockwise will lean the idle mixture. Turning the idle mixture screws counterclockwise will richen the idle mixture.

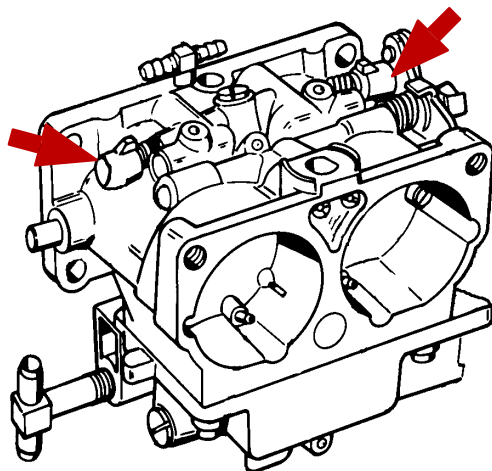

FLOAT LEVEL ADJUSTMENT

There is one float and one float bowl for 2 cylinders. To set float height, invert float bowl and adjust float tang until top of float is even with top of float bowl.

JET LOCATION FOR EACH CYLINDER

Carburetor jets and adjustment screw installed in the starboard side of the carburetor supply fuel to the port cylinder, jets and adjustment screw installed in the port side supply fuel to the starboard cylinder.

NOTE: The idle jet and back draft jet affect both cylinders.



Carburetor Placement and Jet Location for Each Cylinder

TOP

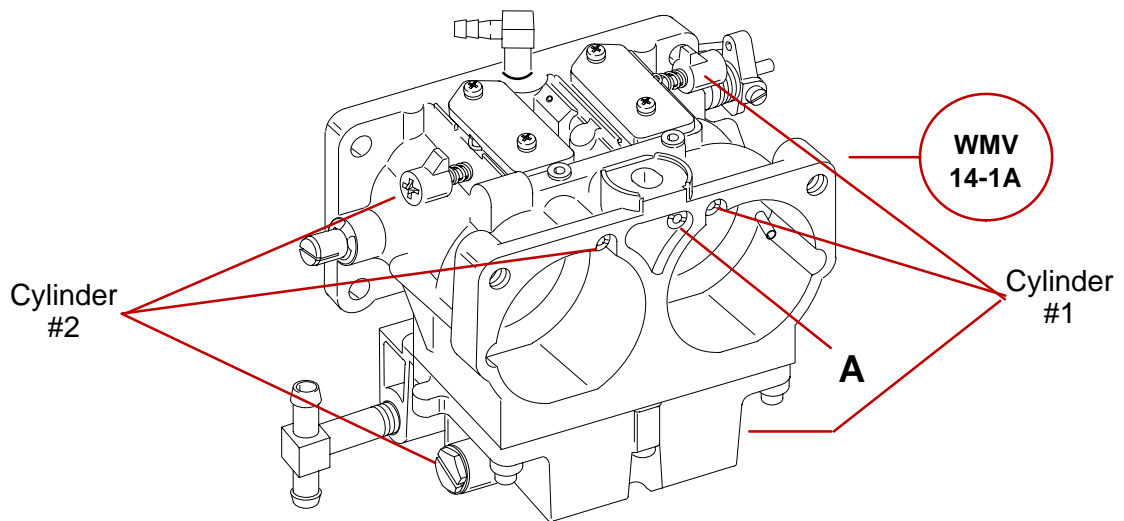

MIDDLE

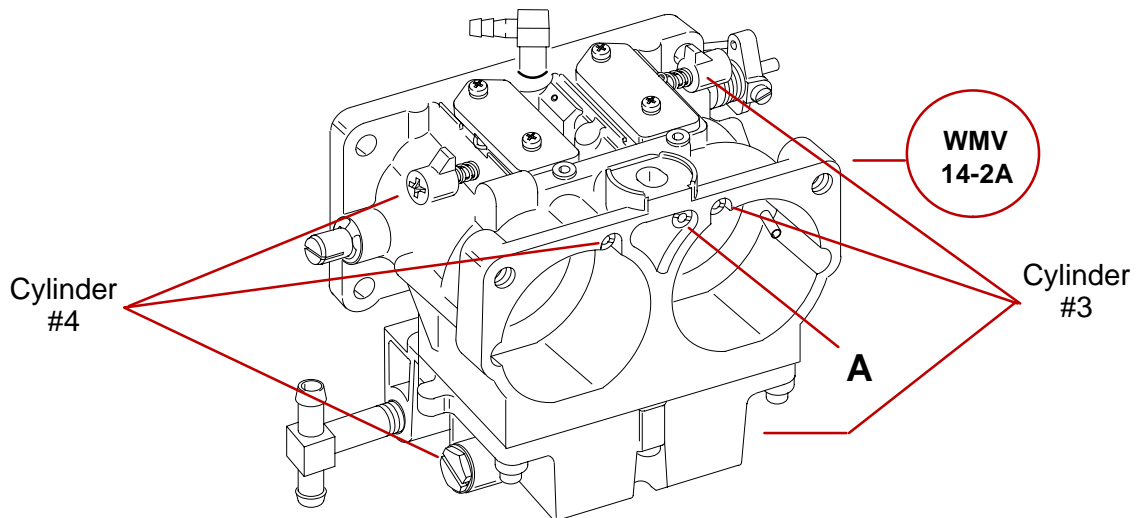

BOTTOM

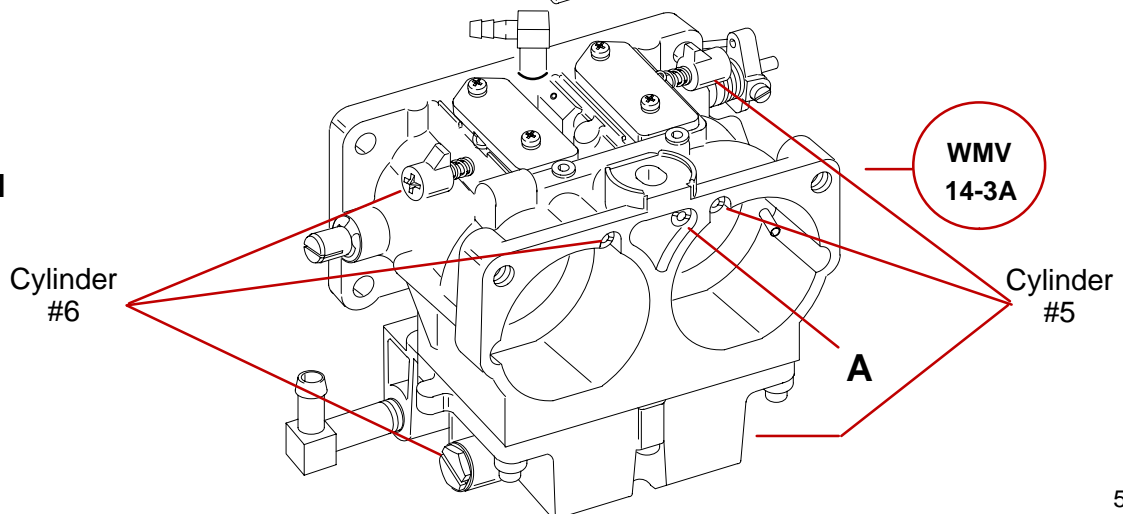

54349

A – Backdraft Jet Affects Both Cylinders

NOTE: Carburetor jets and adjustment screw installed in the starboard side of the carburetor supply fuel to the port cylinder, jets and adjustment screw installed in the port side supply fuel to the starboard cylinder.



Carburetor Jet Placement

Jet Part Number Chart

NOTE: Jets listed are for engine operation from 0–5000 feet (0–1524m) of elevation.

Carburetor Identification Number		Main Jet a	Idle Air Bleed Jet b	Back Draft Vent Jet c
WMV 14-1A	PORT Bore	.082	.054	.080
	STBD Bore	.080	.044	
WMV 14-2A	PORT Bore	.084	.048	.080
	STBD Bore	.086	.048	
WMV 14-3A	PORT Bore	.082	.054	.080
	STBD Bore	.082	.048	

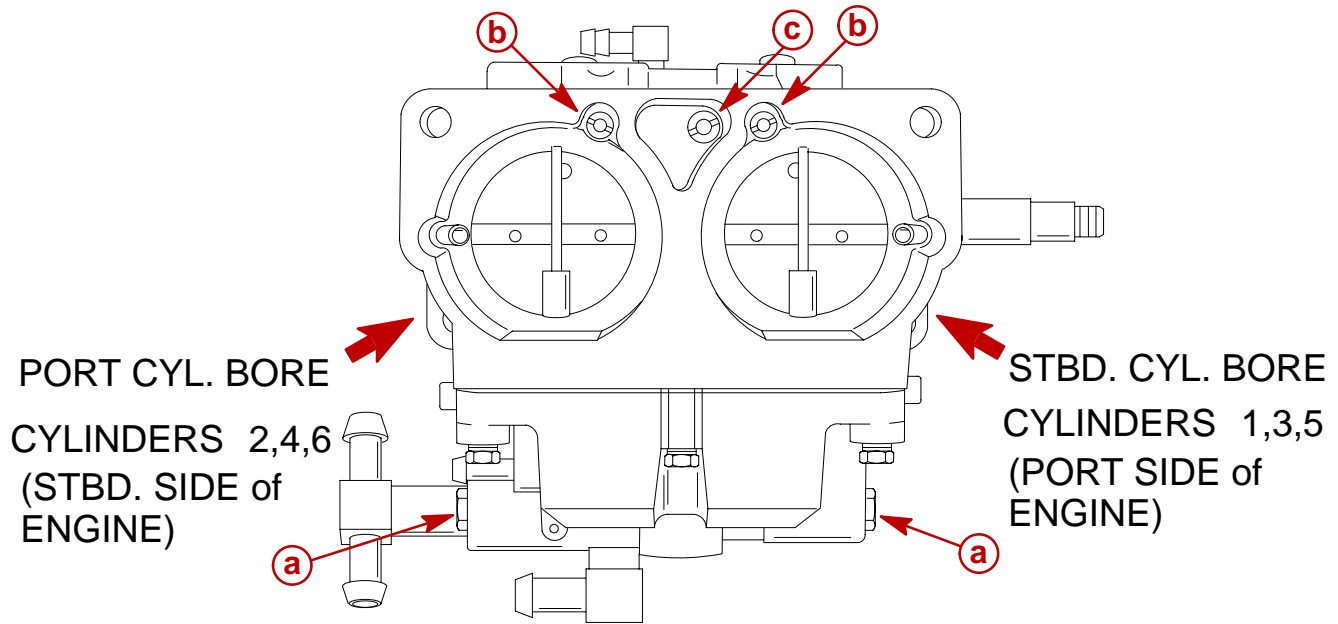



JET ORIFICE SIZE/PART NUMBER CHART 10-32

Jet Orifice Size (inch)	Part Number	Jet Orifice Size (inch)	Part Number	Jet Orifice Size (inch)	Part Number	Jet Orifice Size (inch)	Part Number
.040	19266040	.058	1395-7831	.076	1399-3796	.094	1395-8423
.042	1399-5315	.060	1395-6487	.078	1395-6680	.096	1399-6249
.044	1395-7394	.062	1399-4217	.080	1395-6201	.098	1395-7355
.046	1399-5317	.064	1399-4216	.082	1399-3518		
.048	1395-6246	.066	1399-4215	.084	1399-3517		
.050	1395-6028	.068	1395-6029	.086	1395-5815		
.052	1395-6359	.070	1395-6030	.088	1395-6202		
.054	1399-5225	.072	1395-6207	.090	1395-6247		
.056	1399-5213	.074	1399-3794	.092	1395-5733		

JET ORIFICE SIZE/PART NUMBER CHART 8-32

Jet Orifice Size (inch)	Part Number	Jet Orifice Size (inch)	Part Number	Jet Orifice Size (inch)	Part Number	Jet Orifice Size (inch)	Part Number
.030	810741	.038	815633038	.046	815633046	.054	815633054
.032	1399-3252	.040	1399-7570	.048	815633048	.070	815633070
.034	1395-3251	.042	815633042	.050	815633050	.076	815633076
.036	1399-3026	.044	810742	.052	815633052		

NOTE: Thread size for V-6 model carburetor main, idle air and back draft jets are 10-32

NOTE: Thread size for V-6 model carburetor progression jets are 8-32



Removing Carburetor(s) from Engine

1. Remove top cowling.

IMPORTANT: Place an identifying mark on each carburetor before removal as each carburetor must be reinstalled in same location from which removed.

NOTE: As each carburetor is removed from intake manifold, their respective fuel enrichment hose should be disconnected.

2. Remove air box cover and heat shield from engine.
3. Remove throttle linkage from throttle levers as shown.
4. Remove oil pump link rod from throttle lever.

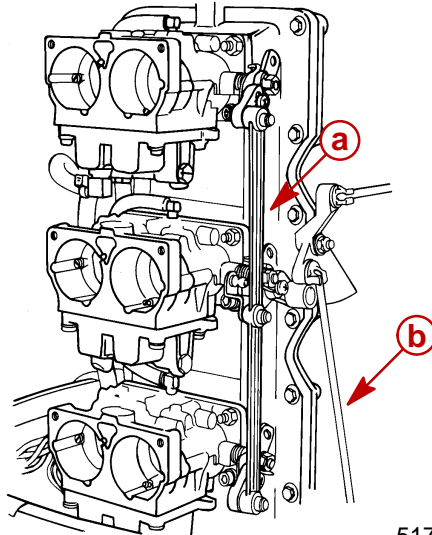

51706

- a** - Throttle Linkage
- b** - Oil Pump Link Rod

5. Remove fuel hose and fuel enrichment valve hose from carburetors.

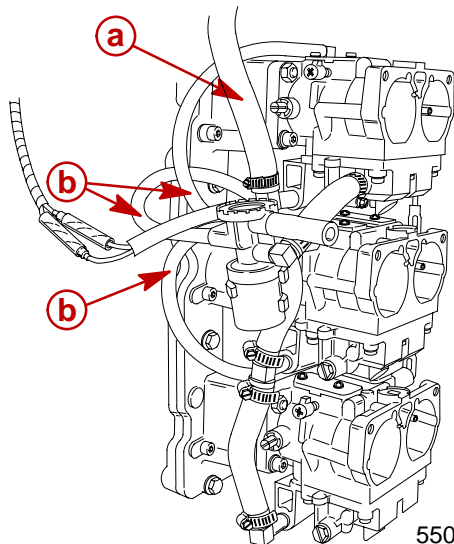

55003

- a** - Fuel Hose
- b** - Enrichment Valve Hoses

6. Carburetors may now be removed individually. Mark location of each carburetor and reinstall in same location. Remove carburetor(s) secured by two nuts and two allen head type bolts.



Throttle Shaft Screws

NOTE: It is recommended that the screws securing the throttle plates to the throttle shaft **NOT BE REMOVED** due to the difficulty in obtaining correct alignment of throttle plates during reassembly. If screws must be removed, apply Loctite 271 to screw threads before reinstalling screws.

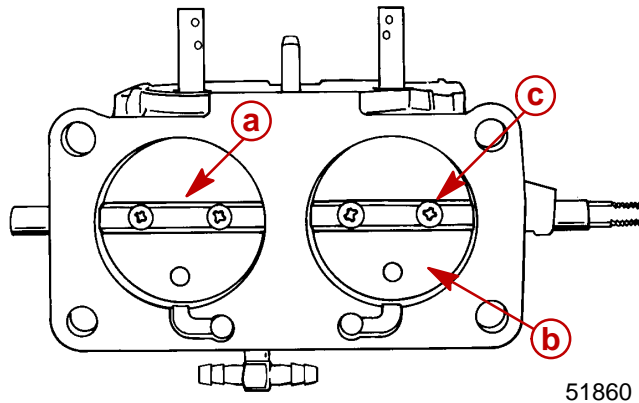

- a** - Throttle Shaft
- b** - Throttle Shutter Plate
- c** - Screws

Float Adjustment

NOTE: Float height adjustment is the only adjustment made to adjust float setting.

1. Adjust float height by turning fuel bowl upside-down, then adjust float tab until float is level with edge of fuel bowl. Adjust float tab if necessary.

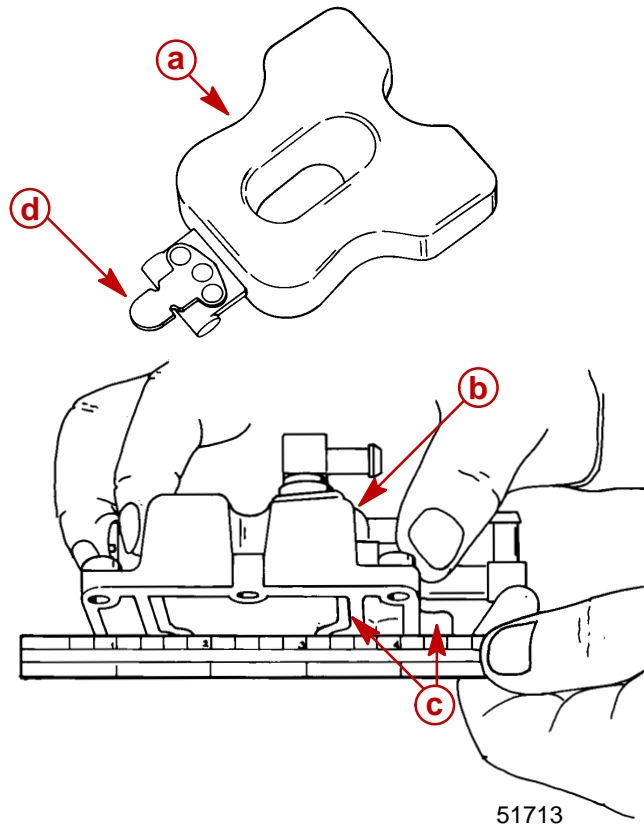

- a** - Float (Adjust by bending tab)
- b** - Fuel Bowl (Upside-Down)
- c** - Float Level Even with Bowl Edge
- d** - Float Tab



Installing Carburetor(s) to Engine

1. Place new carburetor gaskets onto carburetor mounting studs on intake manifold.
2. Install carburetors (in respective locations) onto mounting studs and secure in place with nuts and allen type bolts.
3. Connect enrichment hoses and fuel hoses. Secure hoses in place using sta-straps.

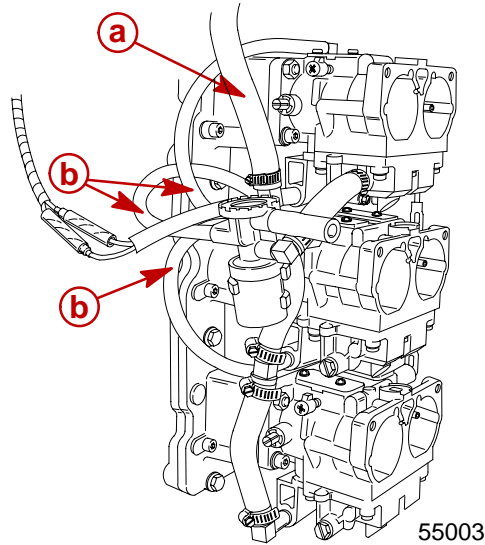

- a** - Fuel Hose
- b** - Enrichment Valve Hose

4. Attach throttle linkage and oil pump link rod to carburetors as shown.

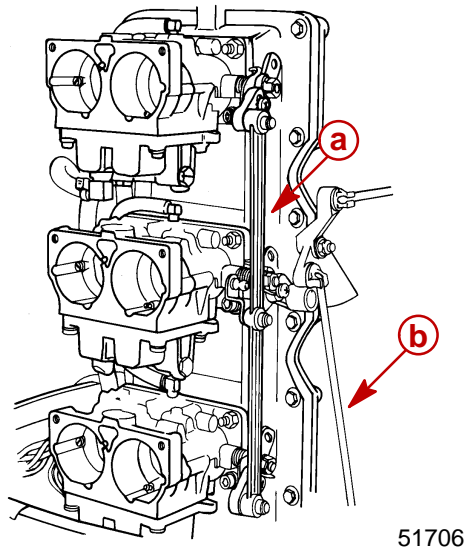

- a** - Throttle Linkage
- b** - Oil Pump Link Rod

5. Re-synchronize carburetors following carburetor installation. Refer to "Timing/Synchronizing/Adjusting" Section 2C.

IMPORTANT: Inspect all fuel hose connections, and carburetor float bowl split lines for fuel leaks with engine running. Also inspect each carburetor throat, with out-board running at low RPM, for fuel dribbling out of vent tube which would be indicative of a float and/or needle and seat assembly not functioning properly.

IMPORTANT: Engine should not be operated above 3000 RPM with air box cover removed as engine will run too lean and internal damage could result.